

Horizontal Concrete Mixing Plants

HN 1 to HN 4 / H5 to H6



SCHWING STETTER MOVES CONCRETE. **WORLDWIDE**

Wherever concrete is produced and moved is where you will find SCHWING - Stetter machinery.

With plants in Germany, Austria, USA, Brazil, Russia, China, and India, as well as with more than 100 sales and service facilities, the group of companies is always close to the customer.

Our wide range of products with something for every application is what makes SCHWING - Stetter the No.1 system supplier for concrete machinery worldwide.

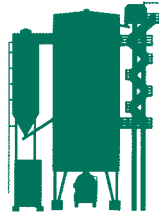

CONCRETE MIXING PLANTS



TRUCK MIXERS



TRUCK-MOUNTED CONCRETE BOOM PUMPS



STATIONARY CONCRETE PUMPS

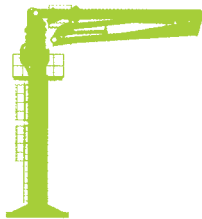

SEPARATE PLACING BOOMS



CONCRETE RECYCLING PLANTS



TOP SHOT RUNNERS

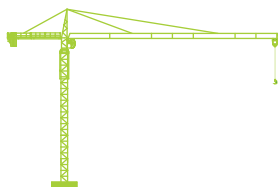

TOWER CRANES

OUR EXPERIENCE COUNTS

Stetter Horizontal Concrete Batching Plants HN 1 to HN 4 and H5 to H6 incorporate the experience of over 74 years in mixing plant technology.

Depending on the requirements, the HN-type series is equipped with a pan mixer or a twin-shaft mixer. While designing the plant, high importance was attached to the access thereby facilitating maintenance. In addition, the generously dimensioned space allows this plant to be offered in a wide variety which can be taken from a modular system. H 5 & H 6 are plants for mass concrete requirements and can be suited to the individual demands by adapting the design.

These high capacity, heavy-duty plants are the first choice wherever large quantities of concrete are required. Small wonder that the Stetter H series plants hold the national records in PQC production (5050 cu.m of concrete in 1 day) and also in dam concrete production (6020 cu.m in 1 day)



The H6 plant at Dankur that set record in PQC production (5050 cu.m in 1 day)



The H6 plant at Subansiri in DAM concrete that set record in PQC production (6020 cu.m in 1 day)

THE HORIZONTAL MIXING PLANTS HN1 to HN4 / H5 to H6
RELIABLE, COST-EFFECTIVE, MODULAR.





THE VERSIONS

IN-LINE SILO, WITH SKIP OR INCLINED BELT CONVEYOR

VERSION 1: IN-LINE SILO WITH SKIP

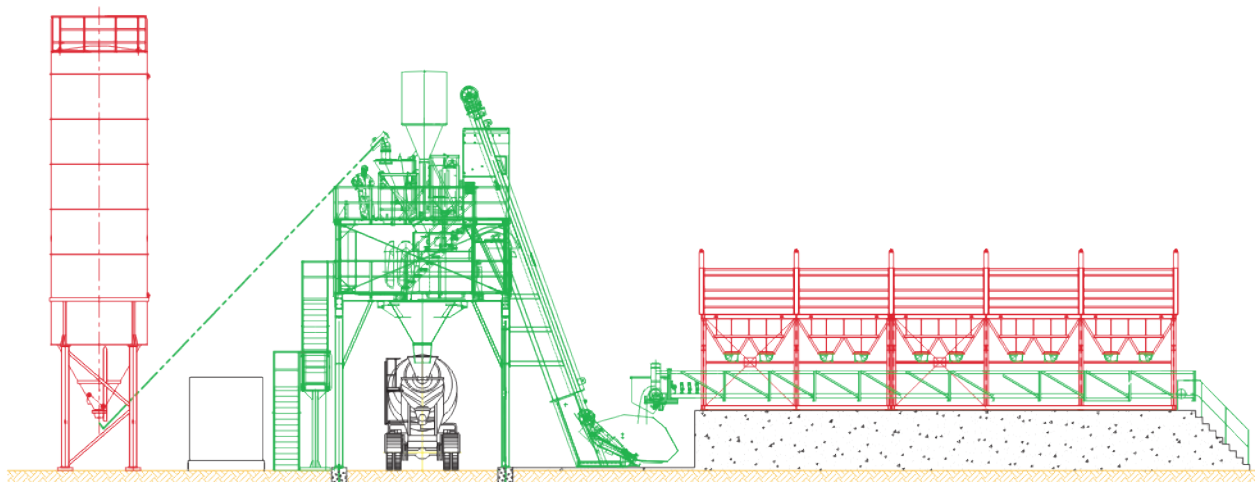

VERSION 2: SEMI-SUNK IN-LINE SILO

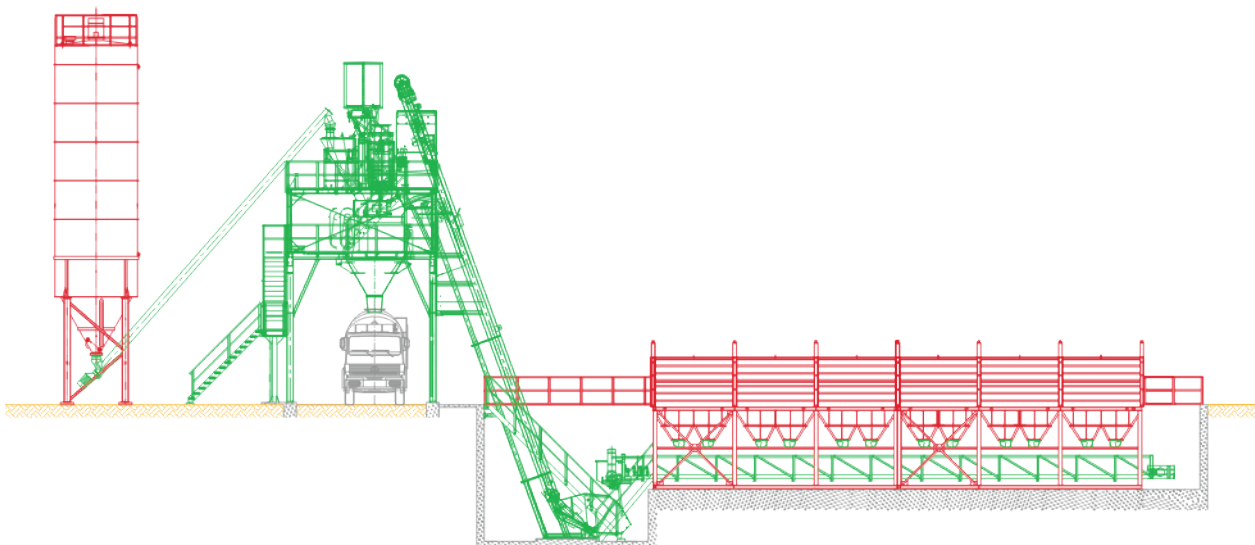

VERSION 3: IN-LINE SILO WITH INCLINED BELT CONVEYOR

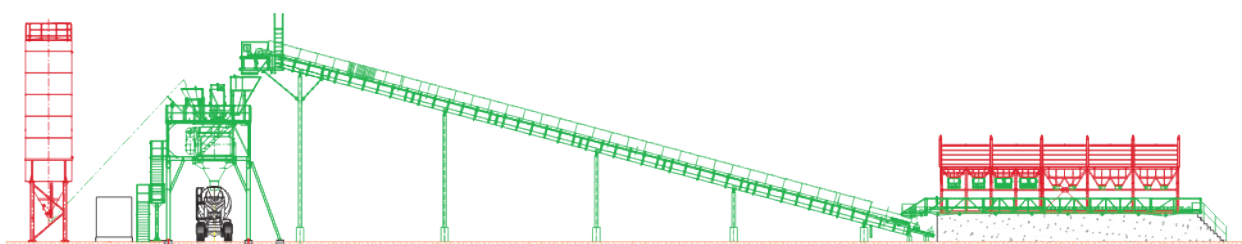

STETTER PAN MIXERS

YOUR GUARANTEE FOR QUALITY CONCRETE

Stetter pan mixers guarantee production of quality concrete in all slump ranges as they mix intensively, thanks to short mixing paths both horizontally and vertically.

Therefore, homogenous concrete is produced with Stetter pan mixers with short mixing times and low energy input. The mixing tools of the Stetter pan mixer are designed for extremely low wear. The spring-mounted mixing arms can be adjusted quickly without difficulty and are protected against wear by polyurethane sleeves. Upon request, our mixers can also be made available with shovels made of syntethic material for particularly long lifetimes instead of the standard mixing shovels made of special chilled cast iron.

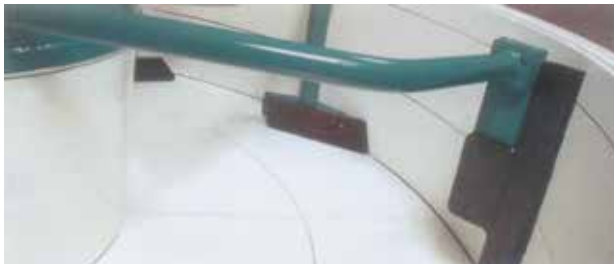

Pictures top left and right : inner and outer scraper support mixing and discharging effect.

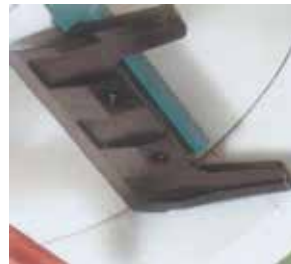

Agitators with reinforced agitating tools experience particularly low wear.

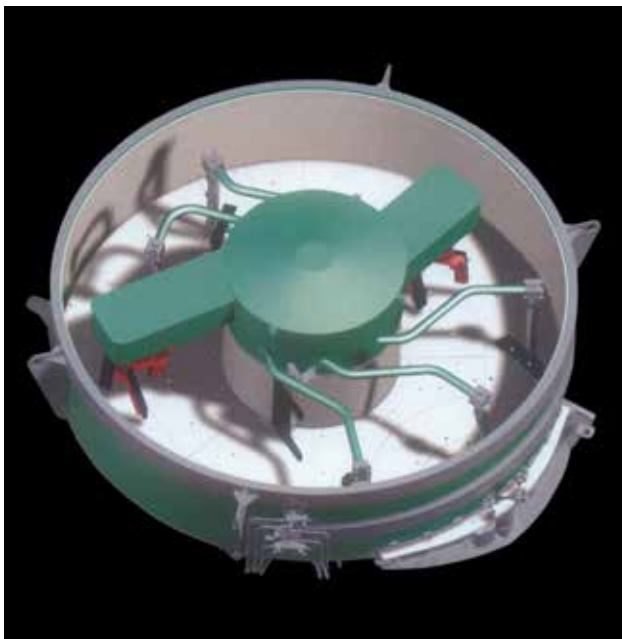

Wherever you employ the pan mixer for production of ready-mix concrete or in precast concrete factories - you produce quality concrete.



Large-dimensional mixer discharge with hydraulically actuated sliding gate for fast discharging.



Power failure? Taking this into account, we have integrated a hydraulically operated manual discharge device.



The drive with planetary gear and flange - mounted hydraulic pump.

The mixing trough is lined with replaceable wear plates on the inner and outer wall as well as on the bottom. The mixing trough bottom can be lined either with normal wear plates made of special steel or special chilled cast iron tiles depending on the characteristics of the aggregates to be handled. The wear plates on the trough outer wall can be turned upside down. Due to all these characteristics we have been able to extend the lifetimes of our mixers considerably.

The pan mixer can be equipped with upto three hydraulically actuated discharge gates which are driven by the mixer motor. The dust-proof mixer cover can be opened up to 70% for maintenance and cleaning.

High-pressure cleaning system is available as additional equipment.

STETTER TWIN-SHAFT MIXER

EXCELLENT MIXING EFFECT AND TIME SAVING

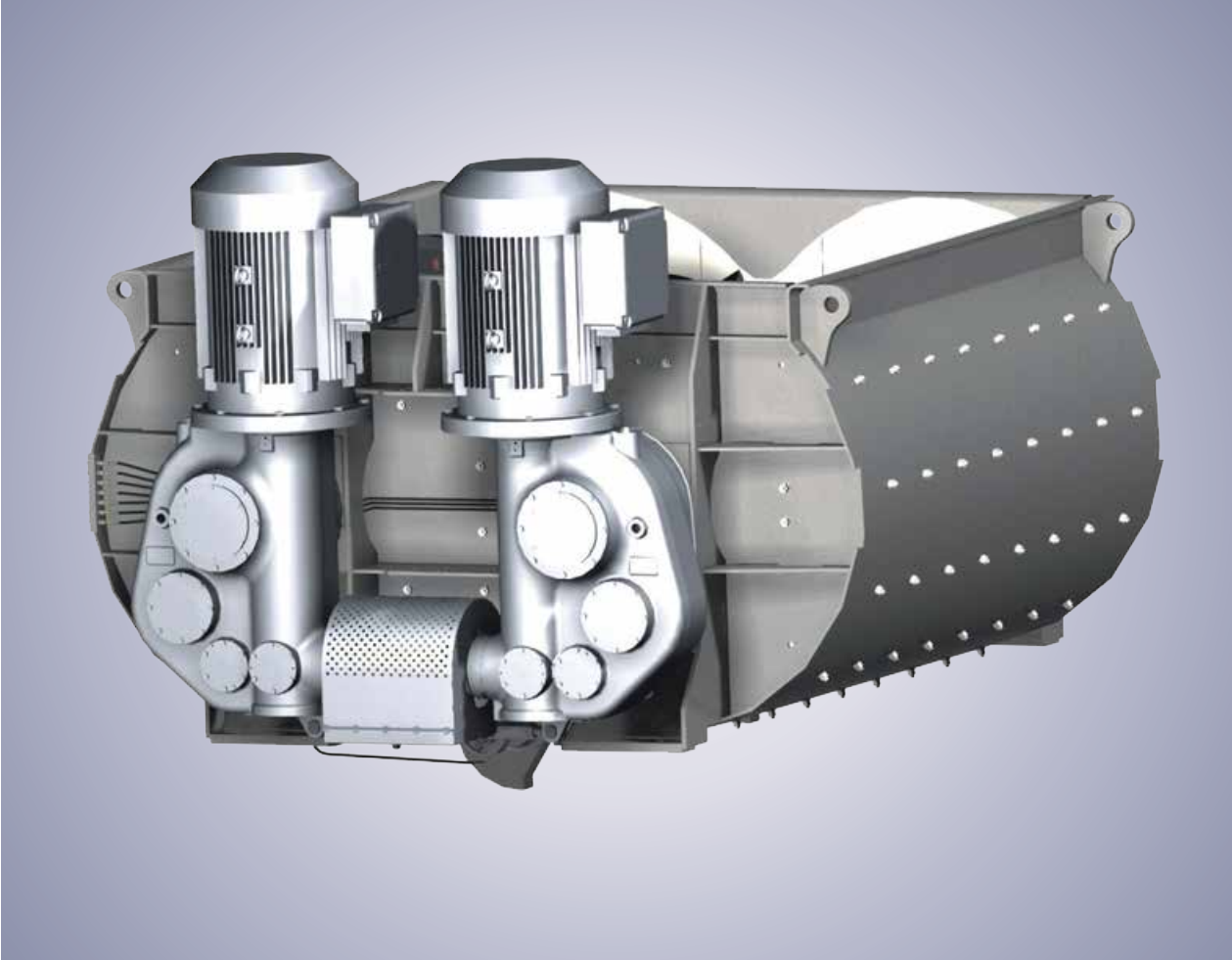

Separataed : sealing and bearing.

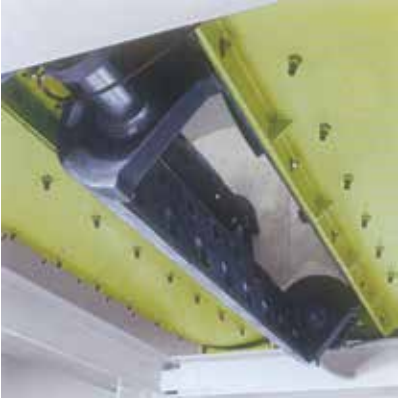

The discharge gate.



The pneumatic discharge gate operation

Excellent mixing effect with short mixing and discharge times, a wide range of applications as well as low wear: these are the characteristics of Stetter twin-shaft mixers compact in design with two mixing shafts rotating against each other, they are made of high-strength heat-treated steel for a long life.

Thanks to Stetter's heavy-duty mixing unit, an intensive agitation of the mixture is reached resulting in fast homogeneity of the mixture. The new compact drive concept offers numerous advantages in daily operation. At first there is an easy access to all components of the mixer for maintenance and repair. And, thanks to the monobloc design with motor and gearbox forming one unit, misalignments and deviations in angles between the axles cannot cause problems.

The mixing arms, made of high-quality cast steel, are arranged on the two hexagonal mixing shafts in a spiral shape. A large overlapping of the tools and a low filling factor were envisaged. An intensive mixing of the concrete is guaranteed together by the flow-supporting blade configuration.

Moreover, the low peripheral speed and the special design of the mixing tools as well as the application of high-quality cast material provide for a long service life of the wear parts.

Even more: the mixing shafts are sealed towards the interior with a slide ring seal. An automatic grease lubrication system can be supplied for these four slide ring seals as an option.

Durable spherical roller bearings are used for the mixing shafts. The bearings are arranged outside of the shaft sealing and accommodated in a separate housing. All these features result in low maintenance requirements and save time and cost.

Optionally available: a special mixing unit for coarse grain for production of dam concrete. This enables the use of aggregates up to a grain size of 150 mm.



The robust and high - capacity mixing unit is designed to be particularly energy saving

SOPHISTICATED IN THE DETAILS

THE HORIZONTAL MIXING PLANTS HN 1.0 HN 4.0



The large - dimensioned skip with an optimum shape guarantees complete emptying.



The mixer discharge for filling truck mixers.



Discharge into open truck.



Dedusting from the mixer



The cement weighing system for up to seven types of cement.



Nozzle heads for cleaning mixer



Admixture weighing system for chemical additives.



Water weighing system with discharge pump for pressurised feeding of water into the mixer .

No matter which plant you opt for:

These are the advantages you receive, thanks to the compact modular system of Stetter horizontal mixing plants:

- Fast erection
- Accessibility all around
- Very spacious and convenient mixer and weighing platform
- Clear arrangement and ease of maintenance
- Optional supply of a mixer ventilation filter
- Optional supply of a mixer cleaning system
- Optional supply of an ice weighing system
- Optional supply of a powder weighing system
- Optionally available with housing
- Optional supply of a camera system for the mixer
- Optional foundations for the complete plant for semi-mobile application

STETTER CONTROL SYSTEM - MCI 460 / MCI 550

QUALITY FROM OWN DEVELOPMENT AND PRODUCTION

MAIN FEATURES OF MCI 460 CONTROL SYSTEM

1. Schedule based batching - Not usable in case of generic interface enabling.
2. Maintenance schedule.
3. Cement batching silo can be changed in between incase of silo empty- Not usable in case of generic interface enabling.
4. Automatic calibration and manual calibration available.
5. All kinds of statistical reports are available.
6. Slump measurement (optional).
7. PID control based batching (addition to the material in air control).
8. Automatic batching after power recovery.
9. Centralized connection of load cell with PLC.
10. Common software for all Stetter plants ranging from M1 to H6.
11. Introduction of touch panel.
12. Introduction of membrane keypad instead of control desk.
13. Connectivity to USB camera (optional).
14. Customer credit locking system (optional)- Not usable in case of generic interface enabling.
15. Provision for slurry water batching.
16. Introduction of authority based password control.
17. Facility to divert the concrete from one customer to another (delivery docket) - Not usable in case of generic interface enabling.
18. Possibility for networking the plants (optional).
19. Option to integrate with SCHWING 996 Weigh Bridge System.

QUALITY AND RELIABILITY

We attach special importance to tried and tested first-class components when selecting the hardware. Only this way are we able to assure you of smooth operation, even under the most difficult conditions. Our control systems are checked with the most modern test and simulation tools during their development, an extensive final testing ensures constant high quality.

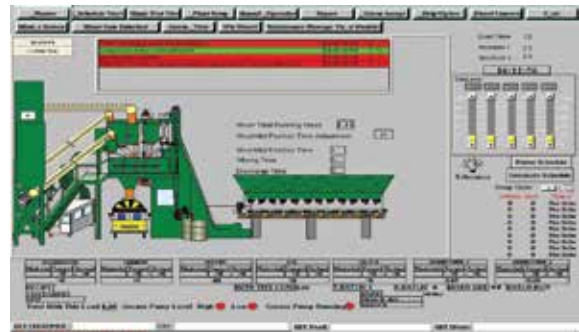

FLEXIBILITY AND INVESTMENT SECURITY

The architecture of our software produced with the most modern methods of development in our own works guarantees the highest flexibility: thanks to their possibilities in configuration, software and system offer simple adaptation to your operating schedule-even if it changes in a few months.

Also, preparation of wiring diagrams and manufacture of switch cabinets is done in our own works. So we can optimally suit the control systems to our concrete mixing plants. Upon request, we integrate our control system also in external installations.

MCI 550 Control System



The MCI550 is the improved version of MCI460. The MCI550 control system is known for its robustness. The main advantage in the system is it doesn't depend on any third party tool or editors to execute. This system is also known for its speed and accuracy.



TECHNICAL DATA

Description	Unit	HN1	HN1.25	HN 2.25	HN 2.5	HN 3.0	HN 4.0	H 5.0	H 6.0
Capacity (compacted concrete with 30 s mixing time)	(m ³ /h)	60	70	100	110	120	150	176	205*
Pan/Planetary mixer (filling/compacted concrete)	(m ³)	1.5 / 1.0	-	3.375 / 2.25					
Twin shaft mixer (filling/compacted concrete)	(m ³)	1.5 / 1.0	1.875 / 1.25	3.375 / 2.25	3.75/2.5	4.5/3	6.0/4.0	7.5/5.0	9.0/6.0
Concrete discharge height	(m)	4.1	4.1	4.2	4.2	4.2	4.2	4.1	4.1
Height of mixer platform	(m)	5.3	5.3	5.9	5.9	5.9	5.9	6.2	6.2
Aggregate weighing system (inline silo)	(kg)	2500	3125	5625	6250	7500	10000	12500	15000
Cement weighing system	(kg)	1125	1125	1125	1500	1500	2100	3000	3000
Water weighing system	(kg)	600	600	600	800	800	1125	1500	1500
Inline silo with capacity (5 bin)	(m ³)	150	150	150	150	150	150	200	200
Filling width of each bin	(m)	3.16	3.16	3.16	3.16	3.16	3.16	3.5	3.5
Types of cement	upto	2/6	2/6	2/6	2/6	2/6	2/6	2/3	2/3
Water connection	DN	80	80	80	80	80	80	100	100
Operating pressure of water	bar	3 to 4	3 to 4	3 to 4	3 to 4	3 to 4	3 to 4	3 to 4	3 to 4
Operating voltage	V	415	415	415	415	415	415	415	415
Admissible voltage fluctuation	%	+/-10	+/-10	+/-10	+/-10	+/-10	+/-10	+/-10	+/-10
Mains frequency	Hz	50	50	50	50	50	50	50	50

Note :

1. Inline silo can be supplied with 4 or 5 or 6 bins based on customer requirement. Increased bin capacities are possible based on customer requirement.
2. HN plants upto the 3 m³ mixer capacity, batching plants are available in both skip and inclined belt conveyor version.
3. From HN 4.0 only inclined belt conveyor version is available
4. *-Discharge into open truck.



Stetter plants are also used for precast applications with Pan / Planetary mixer





STETTER HORIZONTAL MIXING PLANTS

Wherever quality is in demand.



SCHWING - STETTER ALWAYS CLOSE TO THE CUSTOMER.



-  Sales Office
-  Resident Engineer
-  Resident Engineer with Spares Depot
-  Service Centre with Spares Depot
-  Dealership Support
-  Customer Training Center

SCHWING STETTER (INDIA) PVT LTD

An ISO 9001 : 2015 Company

CORPORATE OFFICE : F 71 - 72, SIPCOT Industrial Park, Irungattukottai, Sriperumbudur Taluk, Kancheepuram District, Tamil Nadu - 602117.
Tel : 044 - 71378100 / 106 Fax : 044 27156539
Email : chennai@schwingstetterindia.com

Mumbai : 620/621, Nirmal Lifestyle Corporate Centre, 6th floor, LBS Marg, Mulund (West), Mumbai 400080.
Tel : 022 25624863 / 64, 30718300, 71378100
Fax : 022 25624865 / 66
Email : mumbai@schwingstetterindia.com

New Delhi : 19, Okhla Industrial Estate, Phase III, New Delhi - 110 020.
Tel : 011 30928500 Fax : 011 30928530
Email : newdelhi@schwingstetterindia.com

Kolkata : Y6, Block EP, Sector V, Electronics Complex, Salt Lake City, Kolkata-700091. Tel: 033 40823300
Email : kolkata@schwingstetterindia.com

Hyderabad : No.8-2-268/1/C, Plot 2, Road 3, Arora Colony, Banjara Hills, Hyderabad-500034.
Tel: 040 33555588 / 30948601 Fax: 040 23731770
Email : hyderabad@schwingstetterindia.com

Mohali : D 91-PH-VII, Industrial Area, Mohali, Punjab - 160 055. Tel : 0172 3957500 / 3957501
Email : chandigarh@schwingstetterindia.com

Bengaluru : No 138-B, "UDAYAGIRI COMPLEX", 3rd Phase, KIADB Industrial area, Peenya, Bangalore - 560058.
Tel : 080 3355 5588 Fax : 080 3011 4301
Email : bangalore@schwingstetterindia.com

Visakhapatnam : Plot No.54, IDA - Block 'D', Expansion, Auto nagar, Visakhapatnam - 530 012.
Tel : 09100061783 Fax: 0891 2706063

Jammu : C/o. VRL Logistics Limited, Plot No. 19, Transport Nagar, Narwal, Jammu - 180006.
Tel : 099060 35941.

Ahmedabad : 103, Shivalik Arcade, 100 Ft., T.P Anand Nagar, Satellite Road, Ahmedabad 380 051.
Tel : 079 71378100 Fax : 079 4006 4084
Email : ahmedabad@schwingstetterindia.com

Cochin : No.134 / 1404 B, Arakkakadavu Road, Anchumana, Edappally P.O. Cochin - 682 024.
Tel: 0484 - 3355558 / 4055544 Fax: 0484 4506165
Email : cochin@schwingstetterindia.com

Bhubaneswar : Plot No:182, Naharkanta, Rudrapur, Beside Puri Main Canal, NH5, Bhubaneswar - 752101 Odisha. Tel : 9078884484 / 85

Pune : Baner Biz Bay, A Wing, 7th Floor, Office No. A-701 & 702, Baner Road, Near D-Mart, Pune - 411 045.
Email : pune@schwingstetterindia.com

Coimbatore : 2005, Trichy Road, Old Rajalaxmi Mills, Singanallur, Coimbatore-641005. Tel: 0422 3223660
Email : coimbatore@schwingstetterindia.com

Raipur : NH-6, Opposite Vardhaman Motor, Kumahari, Dist - Durg, Chhattisgarh - 490042.
Tel : 07821 247066
Email : sunil.kumar@schwingstetterindia.com

Patna : C/o. House of Ashok Kumar Rana, Ground & First Floor, Samridhi Bhawan, Agarnkuan Road, Shivaji Colony, Pahari More, Patna - 800007, Bihar. Tel : 09570996702
Email : rajiv.chandra@schwingstetterindia.com

Surat : Shop No. 128, First Floor, Aagam Orchid, TP Scheme No 6, Opp. Shiv Kartik Complex, Off VIP Road, Nr. Shrunagar Building, Nr Nandini 2, Vesu, Surat-395007 Tel : 08980002726
Email : ahmedabad@schwingstetterindia.com

Guwahati : House No. 161, Jaya Nagar, Six Miles, Khanapara, Guwahati 781 022.
Tel: 0361 2234738 / 099575 66738

Goa : C/o Agarwal Packers and Movers Limited, Plot No X-1, Verna Industrial Estate, Verna, Goa - 403722. Tel: 09820203847
Email : sohit.chakhaiyar@schwingstetterindia.com

Nagpur : C/o Amrut Dairy Farm, No. 118, Opp VCA Stadium, Jamtha, 16th KM Milestone, NH-7, Wardha Road, Nagpur - 441108. Tel : 09820203847
Email : sohit.chakhaiyar@schwingstetterindia.com

Indore : Plot No.1074/9/1, A.B. Road (By-Pass), (Opp) Silicon Valley Housing Project, Rau-453331, Indore - 452010. M.P Tel : 8085966587
Email : ahmedabad@schwingstetterindia.com

Jaipur : F-551, Road No. 6, Lehar Choraha, Vishwakarma Industrial Area (VKI Area), Jaipur - 302 013, Rajasthan. Phone: 09672423444